

This TechNote illustrates the basic differences between series and parallel connected 18-pulse rectifier systems as well as the expected performance levels under varying load conditions. The popularity of 18-pulse rectifier topologies has increased in recent years especially in specific industries such as wastewater, HVAC and municipal water purification. These methods have often been chosen due to their theoretical ability to cancel certain harmonics in adjustable speed drive applications. The assumption seems to be made that if a system uses a 18 pulse rectifier, then it will automatically produce very low harmonic distortion. While this may be true under certain circumstances (full load and balanced line voltage), it is not necessarily the case over the wide operating ranges associated with these industries.

### Configuration of Multipulse Bridge Rectifiers

For eighteen pulse drive systems there are two possible connection schemes to consider for the three bridge rectifiers. They can either be connected in series with each other or in parallel with each other. For parallel connection (Fig. 1) the bridge rectifiers will each support full rated voltage but 1/3 rated DC bus current. In most cases, additional reactors are required to achieve balanced current flow thru all bridge rectifiers. Without these, unbalanced current flow can cause 3rd harmonic current to flow in the input circuit. For series connection (Fig. 2), the bridge rectifiers will each support 1/3 of system voltage and full rated DC bus current.

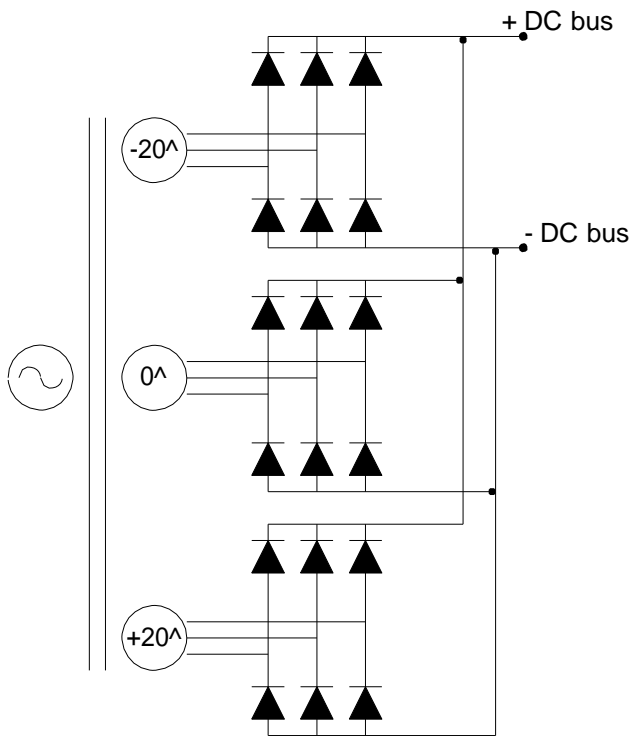

Fig. 1 Parallel connected 18-pulse rectifier

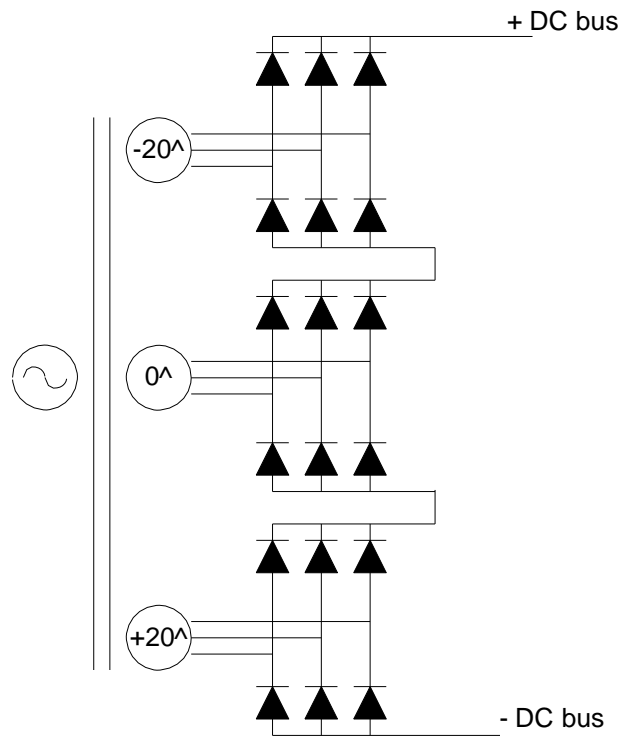

Fig. 2 Series connected 18-pulse rectifier

### Isolation from Power System

Although both methods above are illustrated with isolation transformers, in reality, the parallel connected rectifier method is typically supplied with an autotransformer plus a line reactor, while the series bridge rectifier method is always supplied with an isolation transformer. The series connected rectifiers method will de-couple the drive from the power system through the isolation transformer, and due to the inherent impedance of the isolation transformer, does not require an additional line reactor.

### Efficiency of Parallel vs Series Bridge Rectifiers

When the magnetic components required for balanced current, are considered, efficiency of parallel and series connected systems are quite similar. If balancing reactors are not used, then the parallel method may have 0.75% to 1% higher efficiency, however, one could expect the presence of 3rd harmonics which could have an offsetting effect.

### Parallel Connected Bridge Rectifiers

Three independent phase shifted transformer windings supply the three separate 6-pulse bridge rectifiers which are ultimately connected in parallel with each other. The voltage of each secondary winding is the full voltage rating of the drive, whereas the current rating of each winding and bridge rectifier only needs to support 1/3 of the DC bus current.

The book entitled “High Power Converters and AC Drives”, by Bin Wu illustrates the performance of both series and parallel connected 18-pulse rectifiers for different line inductance ( $L_s$ ) and for various load conditions ( $I_{A1}$ ). Fig. 3 below illustrates the THD performance of parallel connected bridge rectifier type 18-pulse drives, while Fig. 4 illustrates the performance of the series type. While THD may be similar at the 100% load operating point, as current is reduced, the THD for series connected 18-pulse rectifier systems is lower than for parallel connected 18-pulse rectifiers. Best overall THD performance is achieved using series connected 18-pulse rectifiers. Actual test data, shown in Fig. 5 below, measured at a wastewater facility using parallel connected 18-pulse rectifier type drives, is consistent with the chart in Fig. 3.

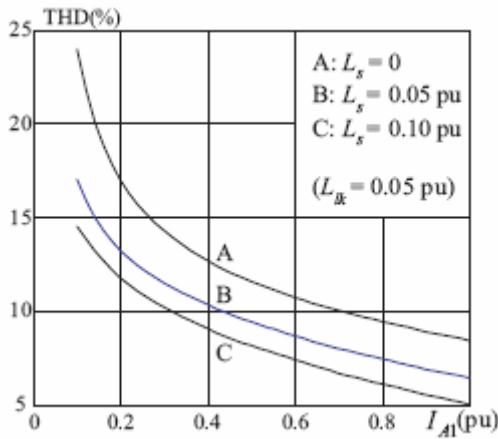

Fig. 3 Performance of PARALLEL connected 18-pulse  
(From “High Power Converters and AC Drives” by Bin Wu)

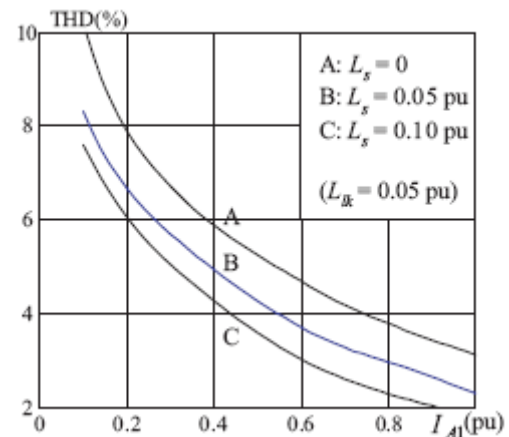

Fig. 4 Performance of SERIES connected 18-pulse  
(From “High Power Converters and AC Drives” by Bin Wu)

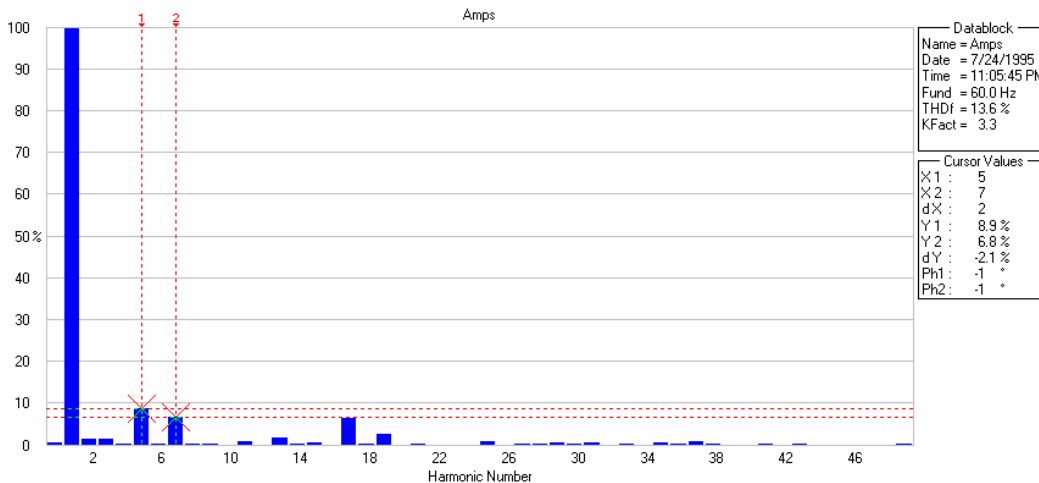

Fig. 5 (Test data: 250HP (parallel bridge 18-pulse) VFD at 35Hz, 92A [34% load] input current) THD-I = 13.6%.

### Series Connected Bridge Rectifiers

Three independent and phase shifted transformer windings supply the three separate 6-pulse bridge rectifiers which are ultimately connected in series with each other. The DC voltages produced by each bridge rectifier, add together, like three batteries connected in series, to achieve full DC bus voltage. The voltage of each secondary winding is 1/3 of the voltage rating of the drive, whereas the current rating of each winding and bridge rectifier needs to support the full DC bus current rating. “The series connected method is very tolerant of imperfections in the AC line voltage source” (Derek Paice; *Clean Power Electronic Converters*).